

## DRIVER, TRACK AND RESULTS

<b>DRIVER</b> Alex Thurston	<b>COUNTRY</b> UK	<b>WEATHER</b> AIR TEMP 15 C	<b>TRACK TEMP</b> <input checked="" type="checkbox"/> DRY <input type="checkbox"/> INTERMEDIATE <input type="checkbox"/> WET
<b>TRACK</b> Cotswolds	<b>TRACTION</b> <input checked="" type="checkbox"/> LOW <input type="checkbox"/> MEDIUM <input type="checkbox"/> HIGH	<b>COMMENTS</b> Sunny but cool track temp	
<b>RACE</b> BRCA RD1	<b>DATE</b> 02/04/17	<b>QUALY POS.</b> 1	<b>QUALY TIME</b> 20 308
<b>STARTING POS.</b> 1		<b>FINAL POS.</b> 1	

FRONT SHOCK ABSORBERS				REAR			
900	cst	OIL	600	cst			
Green	SPRINGS		Pink				
mm REBOUND				mm			
<input type="checkbox"/>	<input checked="" type="checkbox"/>	<input type="checkbox"/>	<input type="checkbox"/>	<input type="checkbox"/>	<input type="checkbox"/>	<input checked="" type="checkbox"/>	<input type="checkbox"/>

FRONT ANTI-ROLL BARS		REAR	
<input type="checkbox"/> SOFT	<input checked="" type="checkbox"/> MEDIUM	<input type="checkbox"/> SOFT	<input checked="" type="checkbox"/> MEDIUM
<input type="checkbox"/> HARD		<input type="checkbox"/> HARD	

FRONT TYRES		REAR	
Contact 5 Spoke	MAKE	Contact 5 Spoke	
32	SHORE	35	
69	DIAMETER	76	
L: 0.9 R: 0.5	5-MIN WEAR	L: 1.1 R: 0.8	

ELECTRONICS	
<b>BATTERY</b> <input checked="" type="checkbox"/> 4S <input type="checkbox"/> 6S	
BRAND Arrowmax	CAPACITY 7800 mAh
<b>MOTOR</b>	
BRAND Hobbywing	TYPE 2600KV
TIMING Standard	
<b>ESC</b>	
BRAND Hobbywing	TYPE XR8 Plus

RATIO CONFIGURATION			
<b>SPUR GEAR</b> 15	teeth	<b>PINION</b> 48	teeth
FINAL DRIVE RATIO		ROLL OUT mm	

CHASSIS PLATE	
<input checked="" type="checkbox"/> ALUMINIUM CHASSIS	<input type="checkbox"/> CARBON CHASSIS

AERODYNAMIC CONFIGURATION	
<b>BODY BRAND</b> PF	<b>BODY POSITION</b> 25 mm
<b>BODY TYPE</b> P909	
<b>BUMPER INSERTS</b> <input checked="" type="checkbox"/> YES <input type="checkbox"/> NO	
<b>AIR TRIM POSITION</b> 6 mm	

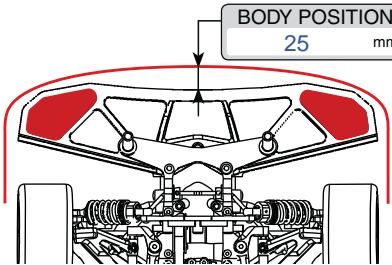

REMARKS	

