

## DRIVER, TRACK AND RESULTS

<b>DRIVER</b> Colin Meijer	<b>COUNTRY</b> France	<b>WEATHER</b> AIR TEMP 26C TRACK TEMP	<input checked="" type="checkbox"/> DRY <input type="checkbox"/> INTERMEDIATE <input type="checkbox"/> WET
<b>RACE</b> Warm UP EURO B	<b>DATE</b> 9 July 2017	<b>QUALY POS.</b>	<b>STARTING POS.</b> <b>FINAL POS.</b> <b>FASTEST LAP</b> 33.05
<b>TRACK</b> ABC Reding France	<b>TYPE</b> <input type="checkbox"/> TIGHT <input checked="" type="checkbox"/> MEDIUM <input type="checkbox"/> OPEN	<b>GRIP</b> <input type="checkbox"/> LOW <input checked="" type="checkbox"/> MEDIUM <input type="checkbox"/> HIGH	
<b>SURFACE CONDITION</b> <input type="checkbox"/> SMOOTH <input checked="" type="checkbox"/> ROUGH <input type="checkbox"/>			
<b>TYPE</b> <input checked="" type="checkbox"/> HARD PACKED <input type="checkbox"/> CLAY <input type="checkbox"/> MULTI/SURFACE <input type="checkbox"/> GRASS <input type="checkbox"/> BLUE GROOVE <input type="checkbox"/> DIRT <input type="checkbox"/> ASTRO-TURF <input type="checkbox"/>			

FRONT SHOCK ABSORBERS		REAR
500 cst	OIL	400 cst
White	SPRINGS	Purple
15 mm	REBOUND	15 mm
N° HOLES 5	Ø 1.5 mm	PISTONS N° HOLES 5 Ø 1.5 mm
<input checked="" type="checkbox"/> BLADDER	SEAL TYPE	<input checked="" type="checkbox"/> BLADDER
<input type="checkbox"/> EMULSION		<input type="checkbox"/> EMULSION

FRONT ANTI-ROLL BARS		REAR
<input type="checkbox"/>	<input type="checkbox"/>	<input type="checkbox"/>
1.8	2.0	2.3
<input type="checkbox"/>	<input checked="" type="checkbox"/>	<input type="checkbox"/>
1.8	2.0	2.3
<input type="checkbox"/>	<input type="checkbox"/>	<input type="checkbox"/>
2.5	2.7	2.5
<input type="checkbox"/>	<input type="checkbox"/>	<input checked="" type="checkbox"/>
2.5	2.7	2.5

DIFFERENTIAL OIL		
<b>FRONT DIFF</b>	<b>CENTER DIFF</b>	<b>REAR DIFF</b>
5000 cst	5000 cst	3000 cst

GEARING	
<b>CLUTCH BELL</b> 13 Teeth	<b>SPUR GEAR</b> 46 Teeth

CLUTCH	
<input checked="" type="checkbox"/> CLUTCH BELL STANDARD <input type="checkbox"/> VENTED	<input type="checkbox"/> FLYWHEEL STEEL <input checked="" type="checkbox"/> ALU
<b>CLUTCH SHOES</b>	<b>CLUTCH SPRINGS</b>
SHOE TYPE <u>Alu</u> x <u>4</u> with SPRINGS TYPE <u>1.1</u> mm	
SHOE TYPE <u>    </u> x <u>    </u> with SPRINGS TYPE <u>    </u> mm	

ENGINE, PIPE AND FUEL			
<b>ENGINE BRAND</b> VS	<b>TYPE</b>	B01	
HEADSHIMS mm	GLOWPLUG P3	CARB Ø	6 mm
<b>EXHAUST PIPE</b> Hipex	<b>MANIFOLD</b> Hipex		
<b>FUEL BRAND</b> Hot Fire	<b>NITRO</b> 25 %		

FLEX CONFIGURATION	
<b>ENGINE MOUNT</b>	<input checked="" type="checkbox"/> STANDARD <input type="checkbox"/> MONOBLOCK

AERODYNAMIC CONFIGURATION	
<b>BODY</b>	<input checked="" type="checkbox"/> STANDARD <input type="checkbox"/> HIGH DOWNFORCE <input type="checkbox"/> OTHER Serpent 600718
<b>WING</b>	
TYPE Serpent 600825	WING PLATES <input checked="" type="checkbox"/> 2° <input type="checkbox"/> 4° <input type="checkbox"/> 6°
GURNEY STRIP <input type="checkbox"/> YES <input checked="" type="checkbox"/> NO	CENTER FOIL <input type="checkbox"/> YES <input checked="" type="checkbox"/> NO

FRONT TIRES		Controlled Tire	REAR
6MIK	MAKE	<input type="checkbox"/>	6MIK
Rapid	TYPE		Rapid
6MIK	INSERTS		6MIK
6MIK	WHEELS		6MIK

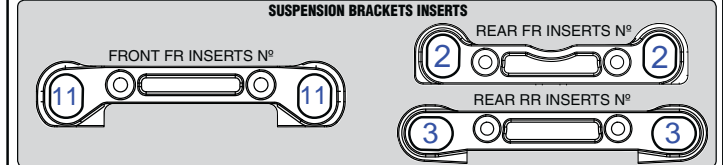
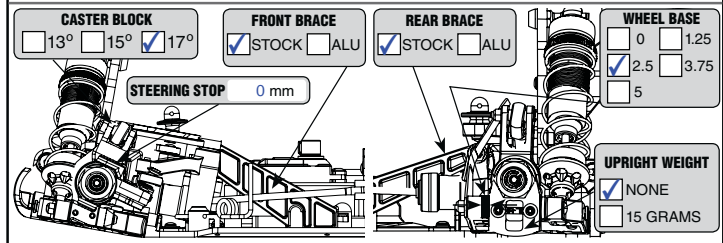
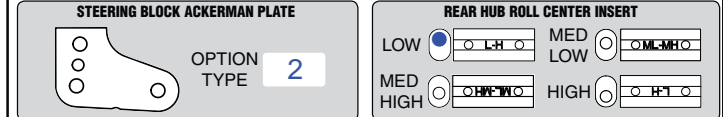
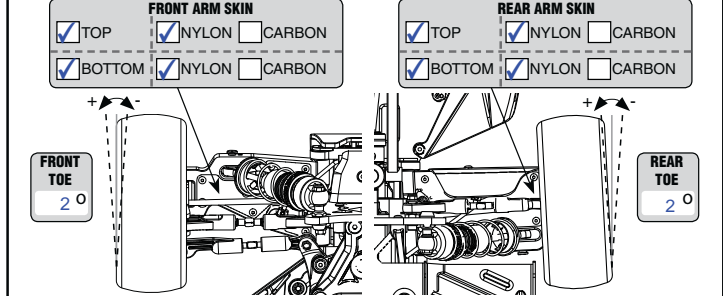
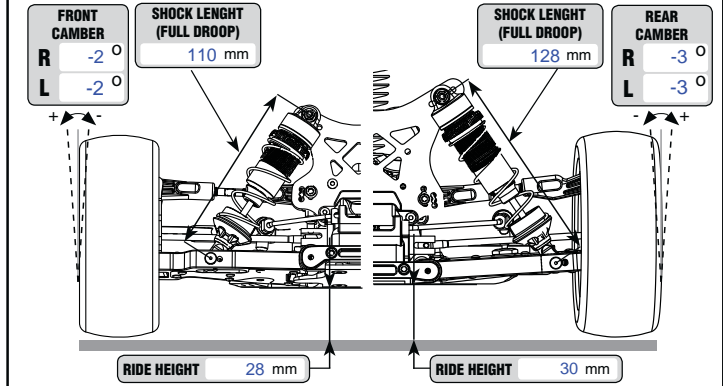
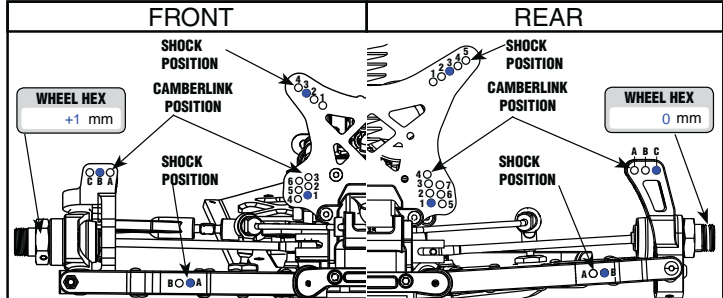

**REMARKS** 15 grams weight between engine mount and rear diff house.