

DRIVER, TRACK AND RESULTS

DRIVER Ralph Burch **COUNTRY** US **WEATHER** AIR TEMP 80 TRACK TEMP 120 DRY INTERMEDIATE WET
TRACK Timezone **TRACTION** LOW MEDIUM HIGH **COMMENTS**
RACE Timezone GP **DATE** 07/16/2017 **QUALY POS.** 1st **QUALY TIME** **STARTING POS.** 1st **FINAL POS.** 1st

FRONT		DRIVE TRAIN		REAR	
<input type="checkbox"/>	GEAR DIFF	<u>cst</u>	<input type="checkbox"/>	GEAR DIFF	<u>cst</u>
<input checked="" type="checkbox"/>		SPOOL			

1ST		SPUR GEARS		2ND	
<input type="checkbox"/>	58	<input checked="" type="checkbox"/>	59	<input type="checkbox"/>	60
<input type="checkbox"/>	53	<input type="checkbox"/>	54	<input checked="" type="checkbox"/>	55

1ST		PINION		2ND	
<input type="checkbox"/>	15	<input type="checkbox"/>	16	<input checked="" type="checkbox"/>	17
<input type="checkbox"/>	20	<input type="checkbox"/>	21	<input checked="" type="checkbox"/>	22

FRONT		SHOCK ABSORBERS		REAR	
<u>1000</u>	<u>cst</u>	<u>OIL</u>	<u>800</u>	<u>cst</u>	
<u>blue</u>	<u>SPRINGS</u>	<u>pink</u>			
<u>3mm</u>	<u>mm</u>	<u>REBOUND</u>	<u>3mm</u>	<u>mm</u>	
<input type="checkbox"/>	<input type="checkbox"/>	<input checked="" type="checkbox"/>	<input type="checkbox"/>	<input type="checkbox"/>	<input checked="" type="checkbox"/>

FRONT		ANTI-ROLL BARS		REAR	
<input type="checkbox"/>	1.8	<input checked="" type="checkbox"/>	2.2	<input type="checkbox"/>	1.6
<input type="checkbox"/>	2.5	<input type="checkbox"/>	2.8	<input type="checkbox"/>	1.8
<input type="checkbox"/>	2.0	<input type="checkbox"/>	2.2	<input checked="" type="checkbox"/>	2.0
<input type="checkbox"/>	2.2	<input type="checkbox"/>	2.5	<input type="checkbox"/>	2.2

FRONT		TYRES		Controlled Tyre		REAR	
<u>enneti</u>	<u>MAKE</u>	<u>enneti</u>					
<u>32</u>	<u>SHORE</u>	<u>37</u>					
<u>60</u>	<u>DIAMETER</u>	<u>61.5</u>					
	<u>5-MIN WEAR</u>						

POWER PACK			
ENGINE			
<u>Picco S1</u>	<u>TYPE</u>		
<u>6</u>	<u>GLOWPLUG</u>	<u>5.4 mm</u>	<u>HEAD CLEARANCE</u> mm
EXAUSHT			
<u>picco 2681</u>	<u>PIPE</u>	<u>picco</u>	<u>MANIFOLD</u>
FUEL			
<u>runner time</u>	<u>BRAND</u>	<u>25%</u>	<u>NITRO</u>

CLUTCH			
<input checked="" type="checkbox"/>	<u>ALU</u>	<input type="checkbox"/>	<u>STEEL</u>
<input checked="" type="checkbox"/>	<u>CLUTCH BELL</u>	<input type="checkbox"/>	<u>RED</u>
<input checked="" type="checkbox"/>	<u>CLUTCH SHOE</u>	<input type="checkbox"/>	<u>YELLOW</u>
<input type="checkbox"/>	<u>CLUTCH SPRING</u>	<u>Serpent hard</u>	<u>CLUTCH BELL GAP</u> .5 mm

FLEX CONFIGURATION			
<input checked="" type="checkbox"/>	<u>CHASSIS STIFFENER</u>	<input type="checkbox"/>	<u>FLEX</u>
<input checked="" type="checkbox"/>	<u>YES</u>	<input type="checkbox"/>	<u>NO</u>
<input type="checkbox"/>	<u>YES</u>	<input checked="" type="checkbox"/>	<u>NO</u>

AERODYNAMIC CONFIGURATION	
<u>Protoform</u>	<u>BODY BRAND</u>
<u>8mm</u>	<u>BODY POSITION</u> mm
<u>P-37</u>	<u>BODY TYPE</u>
<input type="checkbox"/>	<u>BUMPERS HOLES</u>
<input checked="" type="checkbox"/>	<u>YES</u>

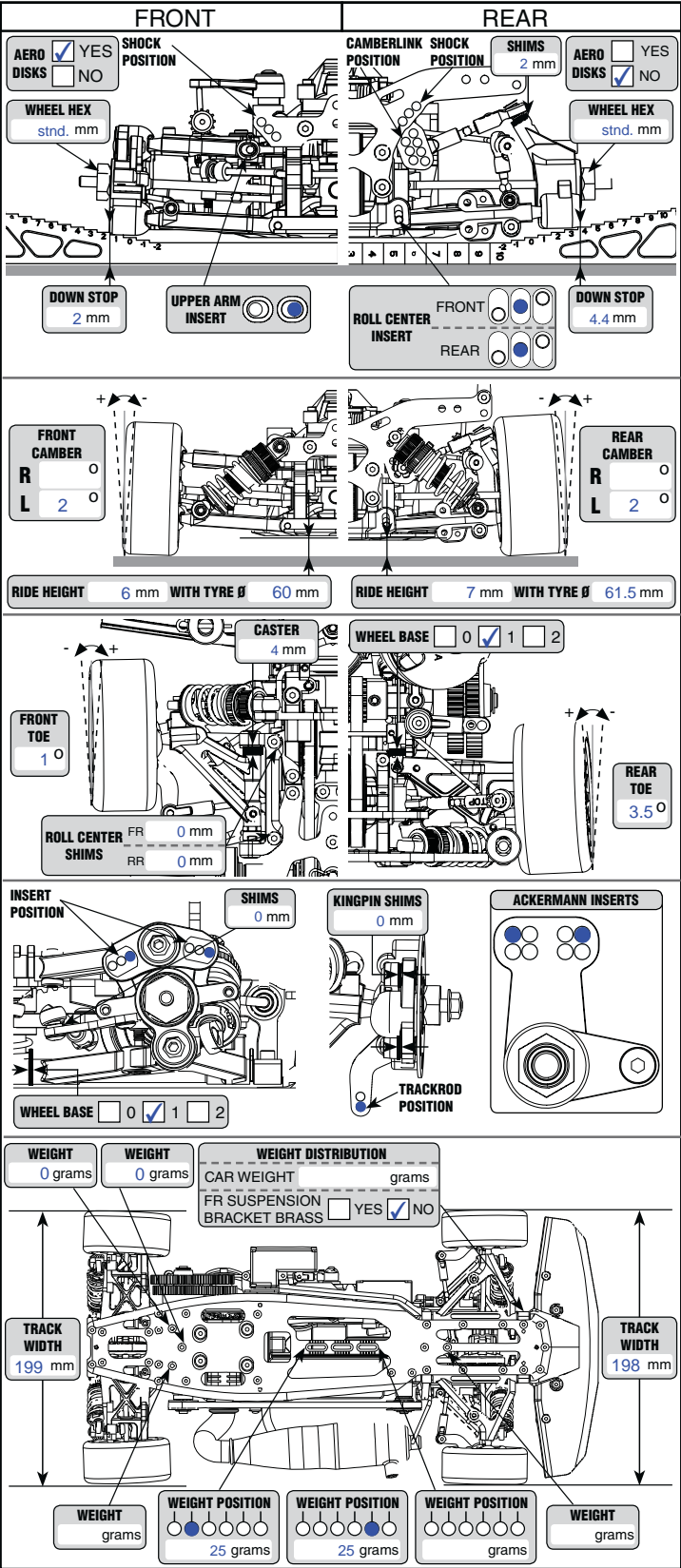

REMARKS 10 gram weight on the bumper