

DRIVER, TRACK AND RESULTS

DRIVER Mark Green **COUNTRY** UK **WEATHER** AIR TEMP TRACK TEMP DRY INTERMEDIATE WET
TRACK Monteux **TRACTION** LOW MEDIUM HIGH **COMMENTS**
RACE WC France **DATE** 9/17-9-2017 **QUALY POS.** **QUALY TIME** **STARTING POS.** **FINAL POS.**

1ST SPUR GEARS 2ND

61 62 63 56 57 58

1ST PINION 2ND

18 19 20 23 24 25

FRONT SHOCK ABSORBERS REAR

AE50 **cst** **OIL** **AE55** **cst**
Green **SPRINGS** **Pink**
 mm **REBOUND** mm

ANTI-ROLL BARS

FRONT ANTI-ROLL BAR 2 **REAR ANTI-ROLL BAR** 3

FRONT TYRES Controlled Tyre REAR

Matrix **MAKE** **Matrix**
32 **SHORE** 35
69 **DIAMETER** 76
5-MIN WEAR

POWER PACK

ENGINE
BRAND XRD **TYPE** FTline
GLOWPLUG XRD 7 **CARBØ** 9 mm **HEAD CLEARANCE** .55 mm
EXHAUST
PIPE XRD 2068 **MANIFOLD** XRD 6
FUEL
BRAND Runner time **NITRO** 16%

CLUTCH

CLUTCH BELL ALU STEEL **CLUTCH SHOE** RED YELLOW BLACK
CLUTCH SPRING X-hard **CLUTCH BELL GAP** 0.6 mm

FLEX CONFIGURATION

FR WISHBONES INSERTS **RR WISHBONES INSERTS** **FLEX**
 PLASTIC CARBON PLASTIC CARBON YES NO

AERODYNAMIC CONFIGURATION

BODY BRAND Protoform **BODY POSITION** mm
BODY TYPE R19
BUMPER INSERTS OPEN CLOSE
AIR TRIM POSITION 10 mm

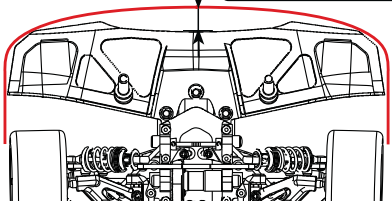
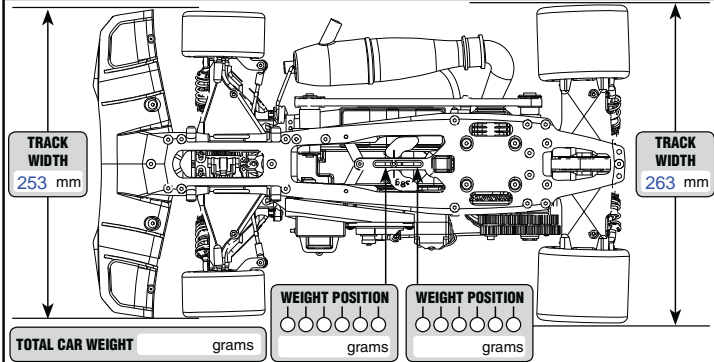
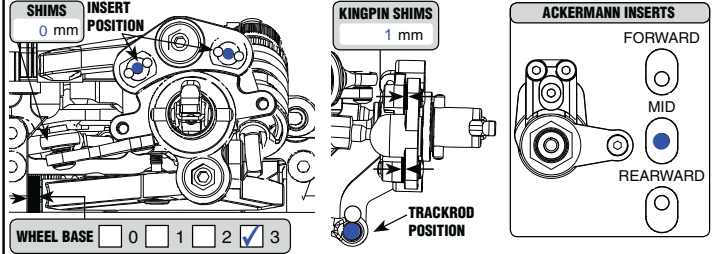
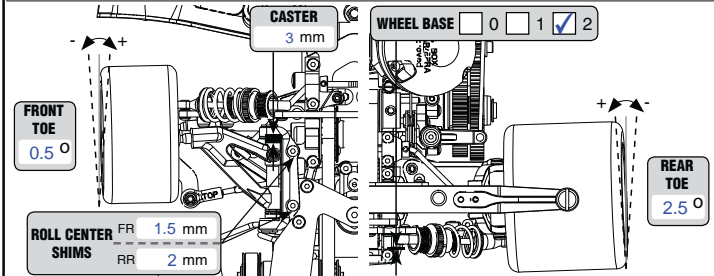
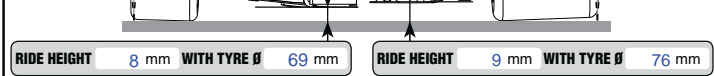
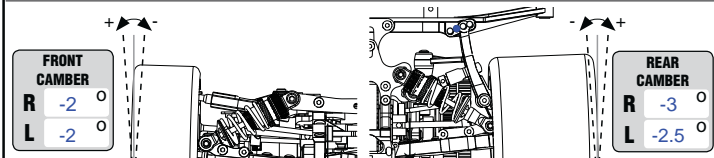
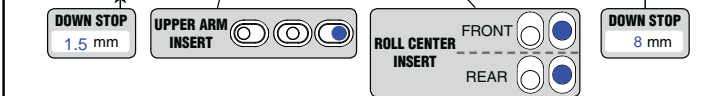
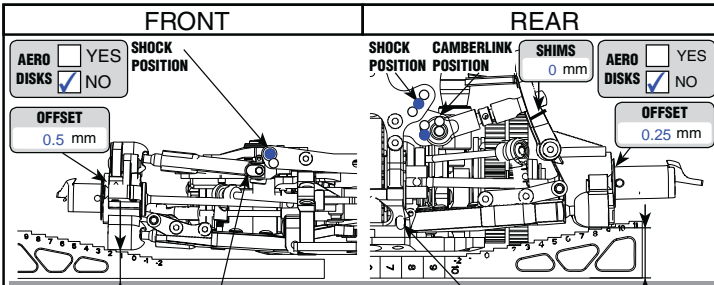
REMARKS

Car balance was always good during the hot and cold conditions. When it was hot i used the AE55 oil in the front shocks. My optionals in the car were alu wheel axes and alu servo saver.