

DRIVER, TRACK AND RESULTS

DRIVER Desoto Jr **COUNTRY** USA **WEATHER** AIR TEMP 80 TRACK TEMP 10 DRY INTERMEDIATE WET
TRACK Toledo **TRACTION** LOW MEDIUM HIGH **COMMENTS** 2017 GLC
RACE 2017 GLC **DATE** 08/25/17 **QUALY POS.** 2 **QUALY TIME** 18 5:06 **STARTING POS.** 2 **FINAL POS.** 2

1ST SPUR GEARS 2ND
 61 62 63 56 57 58

1ST PINION 2ND
 18 19 20 23 24 25

FRONT SHOCK ABSORBERS **REAR**
800 cst OIL 800 cst
Cap 509 Prog. SPRINGS Pink
5 mm REBOUND 5 mm

ANTI-ROLL BARS
 FRONT ANTI-ROLL BAR #2 REAR ANTI-ROLL BAR #3

FRONT TYRES Controlled Tyre **REAR**
Zac MAKE Zac
30/32 SHORE 35/37
66 DIAMETER 73
1.7mm 5-MIN WEAR 2.0mm

POWER PACK
ENGINE
 BRAND Picco TYPE EMX-WC
 GLOWPLUG GS7 CARBØ 9 mm HEAD CLEARANCE 0 mm
EXHAUST
 PIPE Picco 2046 MANIFOLD Picco Performer
FUEL
 BRAND Runner Time NITRO 25%

CLUTCH
 CLUTCH BELL ALU STEEL CLUTCH SHOE RED YELLOW BLACK
 CLUTCH SPRING Spt X-hard CLUTCH BELL GAP 0.9 mm

FLEX CONFIGURATION
 FR WISHBONES INSERTS PLASTIC CARBON PLASTIC CARBON YES NO
 RR WISHBONES INSERTS PLASTIC CARBON YES NO

AERODYNAMIC CONFIGURATION
 BODY BRAND PF BODY POSITION 15 mm
 BODY TYPE R19
 BUMPER INSERTS OPEN CLOSE
 AIR TRIM POSITION 12 mm

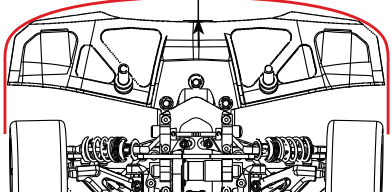
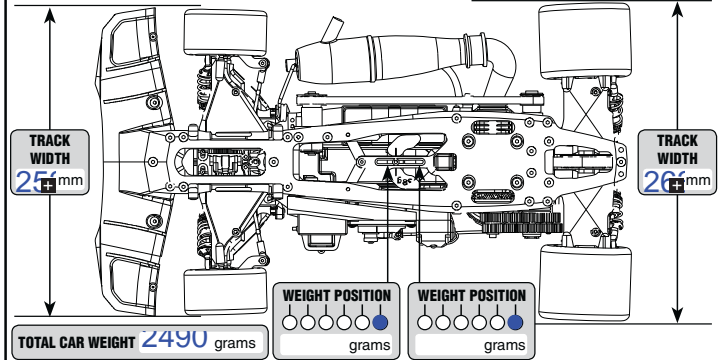
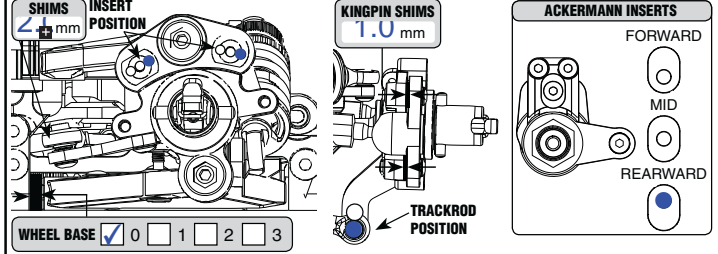
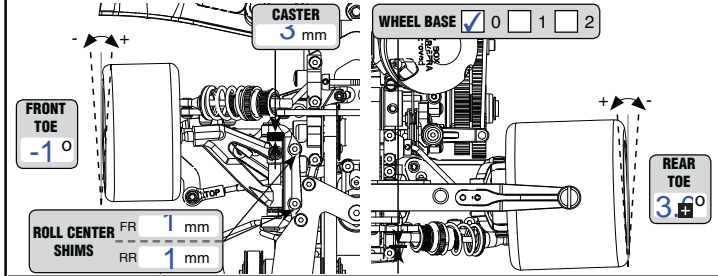
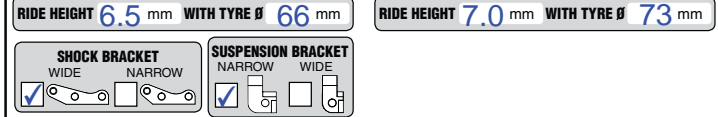
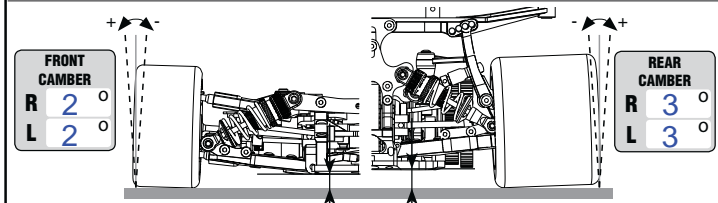
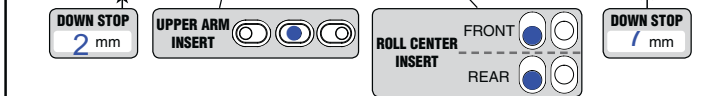
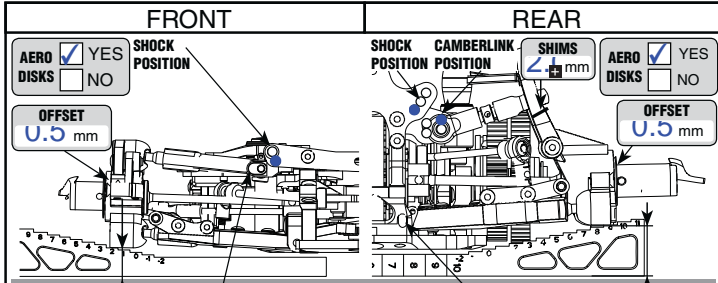
REMARKS