

## DRIVER, TRACK AND RESULTS

<b>DRIVER</b> Pontus Larsson	<b>COUNTRY</b> SWE	<b>WEATHER</b> AIR TEMP 3 TRACK TEMP 3	<input checked="" type="checkbox"/> DRY	<input type="checkbox"/> INTERMEDIATE	<input type="checkbox"/> WET
<b>RACE</b> Practice	<b>DATE</b> 20180127	<b>QUALY POS.</b>	<b>STARTING POS.</b>	<b>FINAL POS.</b>	<b>FASTEST LAP</b> 28,64
<b>TRACK</b> VEDUM	<b>TYPE</b> <input type="checkbox"/> TIGHT <input type="checkbox"/> MEDIUM <input checked="" type="checkbox"/> OPEN	<b>GRIP</b> <input type="checkbox"/> LOW <input type="checkbox"/> MEDIUM <input checked="" type="checkbox"/> HIGH			
<b>SURFACE CONDITION</b> <input checked="" type="checkbox"/> SMOOTH <input type="checkbox"/> ROUGH					
<b>TYPE</b> <input type="checkbox"/> HARD PACKED <input type="checkbox"/> CLAY <input type="checkbox"/> MULTI/SURFACE <input type="checkbox"/> GRASS <input type="checkbox"/> BLUE GROOVE <input type="checkbox"/> DIRT <input checked="" type="checkbox"/> ASTRO-TURF					

FRONT SHOCK ABSORBERS		REAR	
600 cst	OIL	300 cst	
Pink V3 67mm	SPRINGS	Red V3 83mm	
0 mm	REBOUND	0 mm	
N° HOLES 8	Ø 1,3 mm	PISTONS N° HOLES 8	Ø 1,3 mm
<input checked="" type="checkbox"/> BLADDER	SEAL TYPE	<input checked="" type="checkbox"/> BLADDER	EMULSION
<input type="checkbox"/> EMULSION		<input type="checkbox"/> EMULSION	

FRONT ANTI-ROLL BARS		REAR	
<input type="checkbox"/> 1.8	<input type="checkbox"/> 2.0	<input type="checkbox"/> 1.8	<input type="checkbox"/> 2.0
<input checked="" type="checkbox"/> 2.5	<input type="checkbox"/> 2.7	<input checked="" type="checkbox"/> 2.5	<input type="checkbox"/> 2.7

DIFFERENTIAL OIL		
FRONT DIFF	CENTER DIFF	REAR DIFF
10000 cst	10000 cst	7000 cst

GEARING	
CLUTCH BELL	SPUR GEAR
13 Teeth	46 Teeth

CLUTCH	
CLUTCH BELL	FLYWHEEL
<input checked="" type="checkbox"/> STANDARD <input type="checkbox"/> VENTED	<input type="checkbox"/> STEEL <input checked="" type="checkbox"/> ALU
CLUTCH SHOES	CLUTCH SPRINGS
SHOE TYPE alu x 2 with SPRINGS TYPE 0,9 mm	
SHOE TYPE carbon x 2 with SPRINGS TYPE 0,9 mm	

ENGINE, PIPE AND FUEL	
ENGINE BRAND	TYPE
Bullit	B-220
HEADSHIMS 0,2 mm	GLOWPLUG P3
CARB Ø 6,5 mm	
EXHAUST PIPE	MANIFOLD
Bullit 2089	Bullit
FUEL BRAND	NITRO
Hotfire	25 %

FLEX CONFIGURATION	
ENGINE MOUNT	<input checked="" type="checkbox"/> STANDARD <input type="checkbox"/> MONOBLOCK

AERODYNAMIC CONFIGURATION	
BODY	<input type="checkbox"/> STANDARD <input checked="" type="checkbox"/> HIGH DOWNFORCE <input type="checkbox"/> OTHER
<b>WING</b>	
TYPE	WING PLATES
Strait MD	<input type="checkbox"/> 2° <input type="checkbox"/> 4° <input checked="" type="checkbox"/> 6°
GURNEY STRIP	CENTER FOIL
<input type="checkbox"/> YES <input checked="" type="checkbox"/> NO	<input type="checkbox"/> YES <input checked="" type="checkbox"/> NO

FRONT TIRES		REAR	
Schumacher	MAKE	Schumacher	
Minipin	TYPE	Minipin	
Blue	INSERTS	Blue	
Sweep	WHEELS	Sweep	

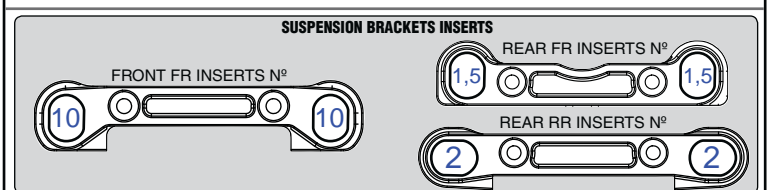
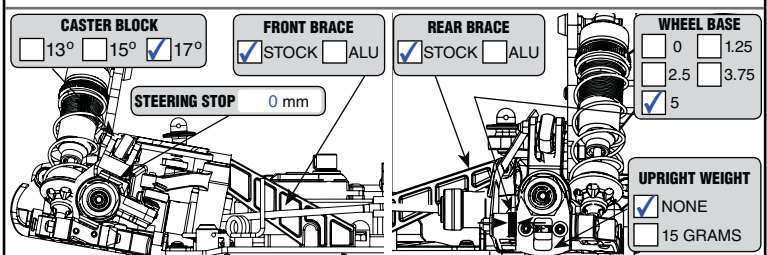
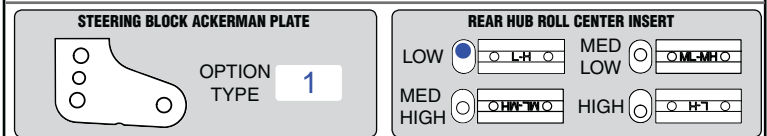
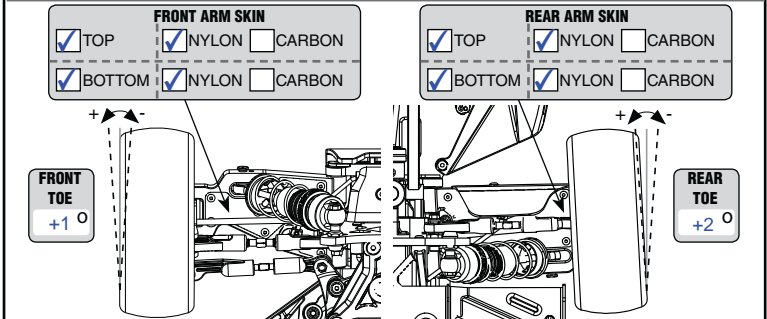
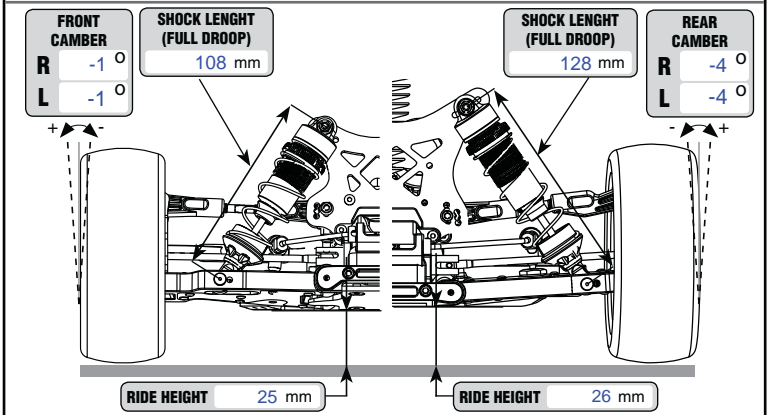
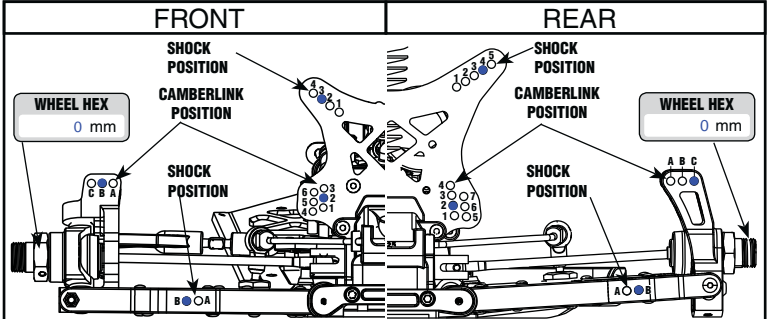

**REMARKS** Middle hole for shock on rear arm, Outside hole for hub on rear arm.  
 Car is good with smooth aceleration and a little to much steering.  
 Next practice: 4 alu shoes, 14T clutch bell, 19 deg caster block, ackerman plate 2. For more speed and easier to drive.